

CITIZEN

**Cincom**

**D25**

Sliding Headstock Type Automatic CNC Lathe



# *Next* Generation

New Concept

New Design

New Operability

New Styling

All-new Cincom D25

Citizen's Challenge The future starts here.



CITIZEN  
Citcom

D25

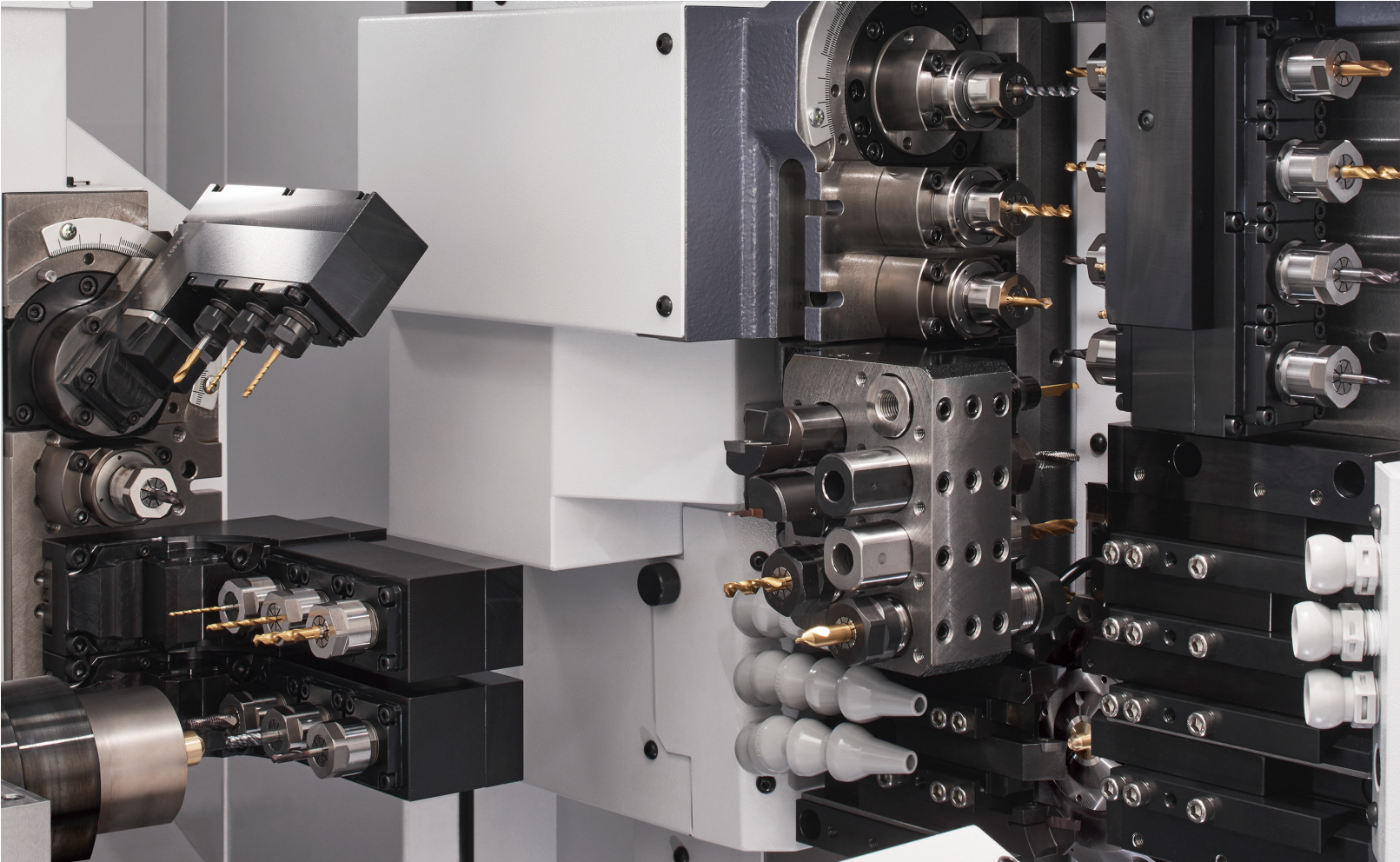

## Full Tool Configuration to Support High Productivity

In addition to the “double gang tool” tool post, a B axis control for front machining is featured. The double gang tool configuration allows the tool post not engaged in machining to be prepared for the next machining, helping to shorten non-cutting time at tool selection, and cycle times. A total of up to 59 front/back tools can be mounted, with up to 28 tools for back machining, enabling a

full range of machining with a diversity of tools and realizing high productivity by optimum division of processes for front/back machining. Complex machining can also be handled flexibly, including contouring on curved faces through simultaneous 5-axis control using the B axis. This presents new machining possibilities.

The machine is configured with two spindles and four tool posts, and tool post 2 features the Z2 axis. Combined with tool post 1, simultaneous machining including balanced cutting and drilling with outer diameter cutting is possible. With type VIII, rotary tools on gang tool post 1 have a B axis, allowing complex machining with an even more comprehensive axis configuration. In addition, both models can be installed with the opposite tool post to realize high productivity with four tool posts.

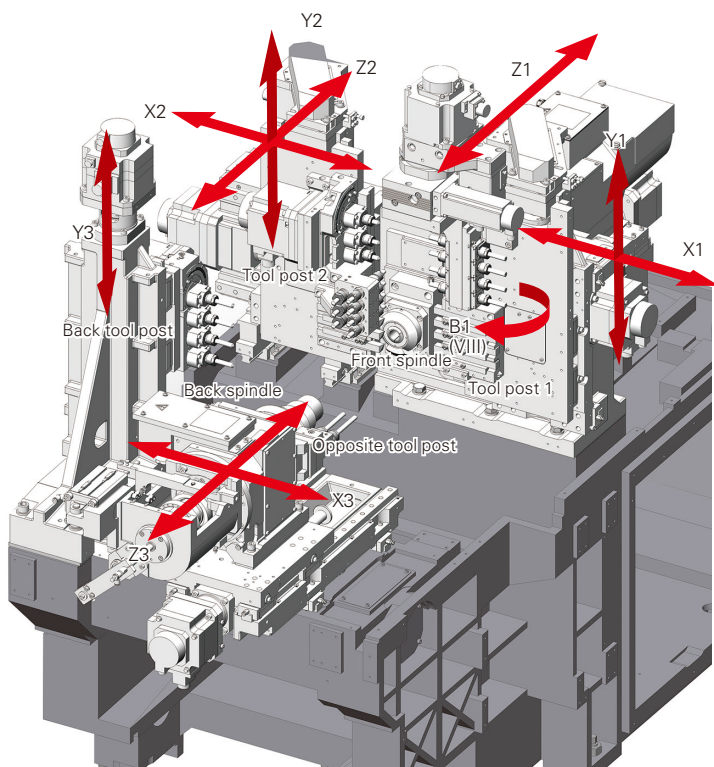

### Axis configuration and model types

	VII	VIII
Rotary tool on the gang tool post (Tool post 1)	T	T
(Tool post 2)	T	T
B axis (rotary tools on the gang tool post)	F	T
Back rotary tool	T	T
Opposite tool post	Opt.	Opt.

## High Productivity through Simultaneous Machining with Three Tools

“Simultaneous machining with three tools” including additional machining with a back tool on the independent back tool post, in addition to simultaneous machining with two tools on the front

face with the double tool post, allows simultaneously machining with turning, drilling, milling and so on, shortening cutting time and achieving high productivity.

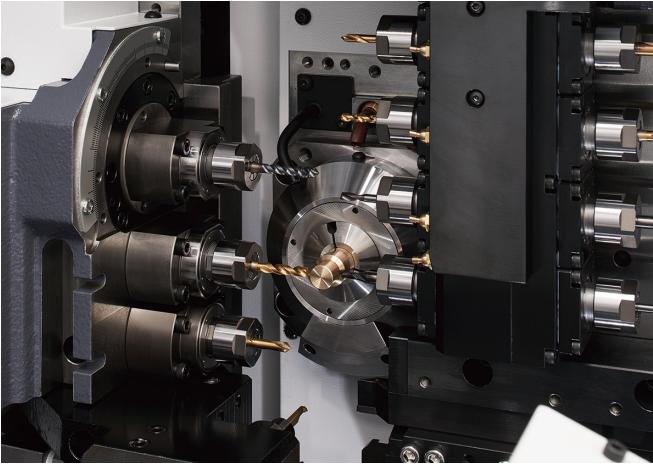

Simultaneous machining with two tools on the front face

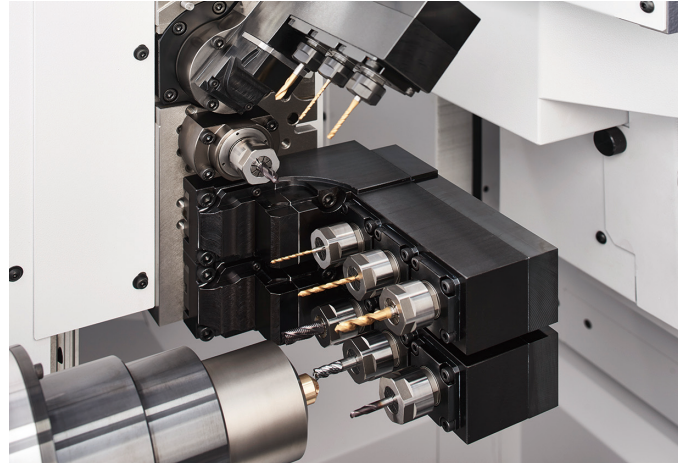

Back machining with the independent back tool post

## B Axis, Supporting Various Inclined Hole Machining (with Type VIII)

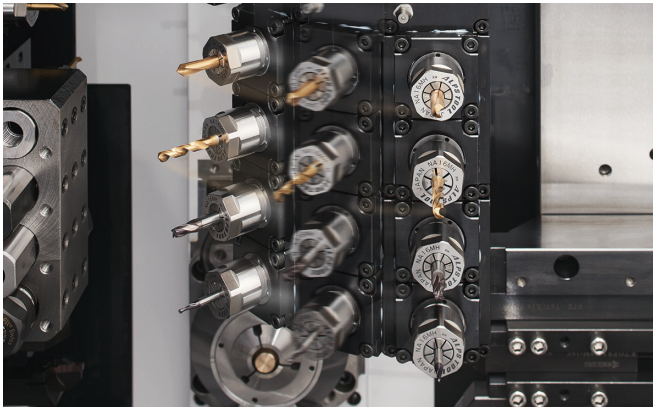

A B axis that can be used for either front or back machining is featured.

It supports a variety of “inclined hole machining” including machining of inclined holes at multiple angles, and helical interpolation machining.

Simultaneous five-axis control with three orthogonal axes and two rotational axes enables machining of complex shapes. The contouring machining function allows machining under the optimum cutting conditions, being able, for example, to maintain the tool angle perpendicular to the machining point even on curved faces.



Drilling a parabolic shape by machining with 5-axis simultaneous control

The range of turning has been further expanded.

## Opposite tool post

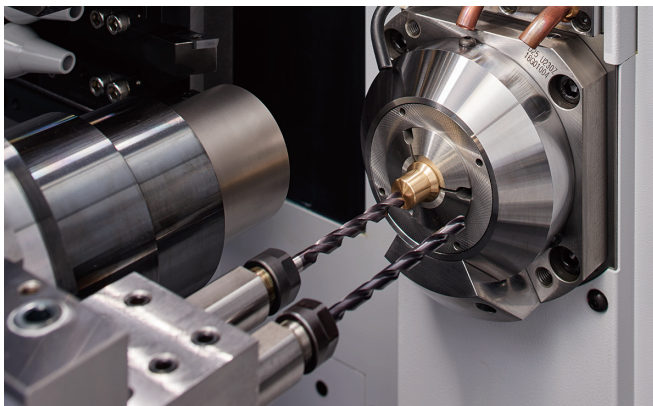

The two drills of the opposite tool post can machine holes up to 100 mm deep.

O.D. cutting can be performed simultaneously even with deep hole machining, further expanding the machining range.

# LFV Technology (optional)



LFV\* is a technology for performing machining while vibrating the X and Z servo axes in the cutting direction in synchrony with the rotation of the spindle. It lessens the various problems caused by chips entangling with the product or tool, and is effective for small-diameter deep hole machining and the machining of difficult-to-cut materials.

\*LFV is a registered trademark of Citizen Watch Co., Ltd.

## Vibration mode

	LFV mode 1	LFV mode 2	LFV mode 3
Operation	Multiple vibrations per spindle revolution	Multiple spindle revolutions per vibration	Vibration threading
Specification	The axes execute multiple vibrations during one spindle revolution, reliably breaking chips up into small pieces.	Machining is carried out while rotating the spindle multiple revolutions per vibration.	A vibrating behavior is applied in the direction of the cutting (notching) during threading with the timing of this vibration changing with each pass in relation to the rotary phase of the spindle to provide "air-cutting" during the machining and break up chips.
Application	Ideal for outer/inner diameter machining and groove machining	Ideal for micro-drilling, where peripheral speed is required	Optimal for threading of internal and external diameters
Waveform			

Note 1: LFV machining can be performed with the X1, Z1, X3, Z3 axis. Note 2: LFV machining can be performed simultaneously on a maximum of 1 pair of axes.

Note 3: For LFV machining with rotary tools, the "LFV function" and "rotary tool feed per revolution" options are required.

## Evolved Operation Panel

The machine features a large 15-inch LCD touch panel screen. The graphical HMI (human machine interface) improves visibility and allows intuitive operation. For even better ease of use, a full keyboard is

integrated in sheet keys. You can select either of two key arrangements: conventional or computer keyboard. NC programs can be input/output using a USB flash drive or SD card.



Operation panel  
The combination of a full keyboard and 15-inch screen assures ease of use.



USB slot and SD card slot  
External output operation using an SD card is supported.

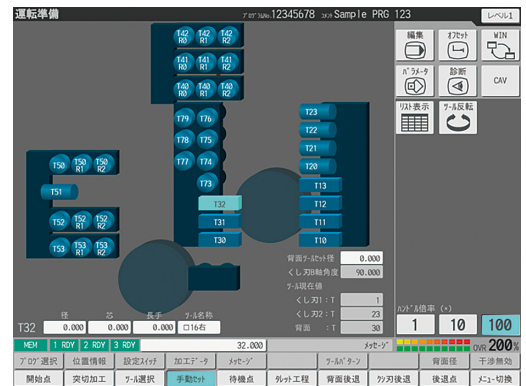

Preparation screen  
Screen design evolved for good visibility while maintaining the renowned operability of the Cincom brand.

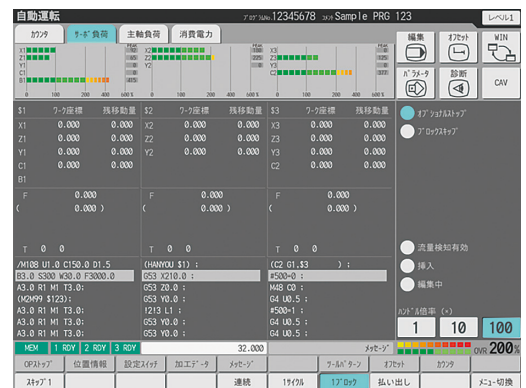

Automatic operation screen  
Motor load information is displayed graphically, allowing intuitive status checks.

# Comprehensive Standard Features

Front/back spindles and rotary tools are equipped with motors of ample capacity. Their comprehensive machining capabilities help improve productivity. Spindle selection specifications are standard too, allowing you to switch between the guide bushing type\*1 suited to machining long workpieces and the guide bushing-less type suited to leaving short

remnant bars. By making use of their features in accordance with the cutting conditions, the total running costs can be reduced. The cutting room door assures an expansive, open operating space for good usability, facilitating the operator's work, such as mount tools.

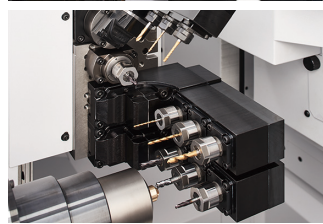
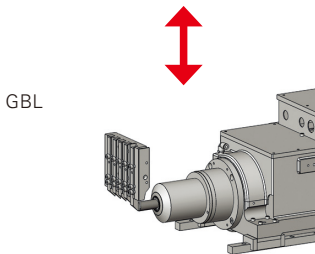
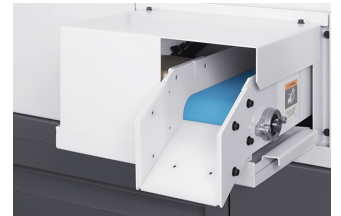
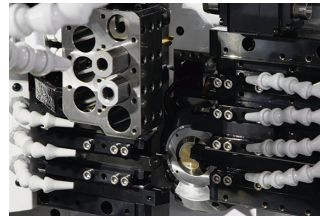
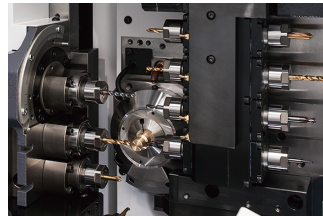
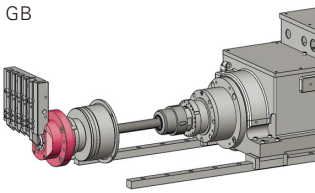

**Workpiece conveyor**  
Unloads workpieces received from the workpiece separator outside the machine.

**Switching between guide bushing/ guide bushing-less type**  
The type can be selected as appropriate, for machining long thin workpieces, when using cold drawn material, or in order to leave short remnant bars.

**Higher level of motor output**  
The motors of front/back spindles and rotary tools have the machining capability of larger-diameter models, are more versatile due to an expanded speed range, and also help to shorten cycle times.

**Coolant nozzles and coolant pumps**  
As a measure against entangling chips, an adequate number of chip coolant nozzles is provided. Furthermore, two pumps are installed to resolve the issue of chip entanglement.



**Wide opening**  
The flip-up door provides good access inside the machine and ample working space.

## Machine Layout Drawing

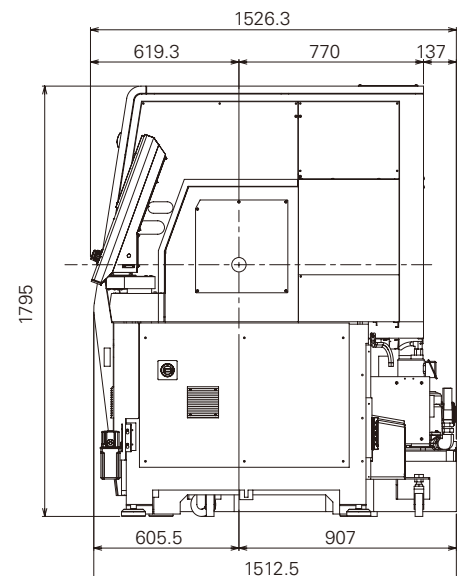
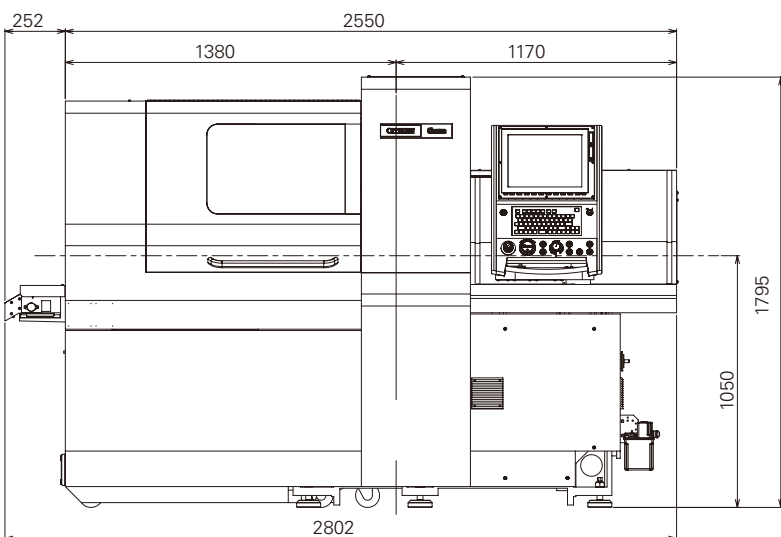
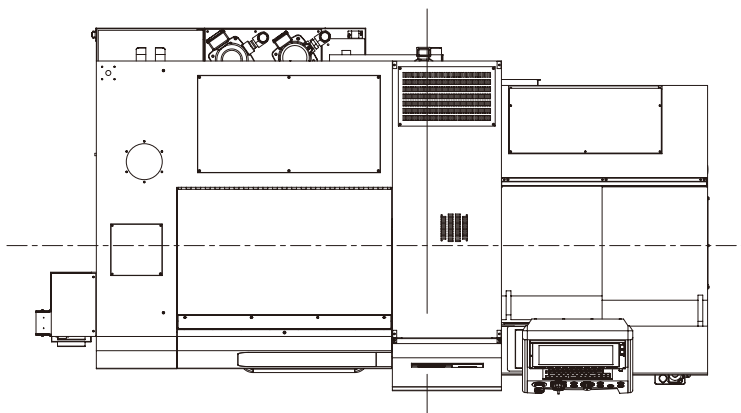

# Machine Specifications

Items	D25	
	Type VII (D25-1M7)	Type VIII (D25-1M8)
Max. machining diameter (D)	25 mm dia.	
Max. machining length (L)		
Guide bushing	250 mm	
Guide bushing-less	2.5 D	
Max. front drilling diameter	12 mm dia.	
Max. front tapping diameter (Cutting tap)	M10	
Spindle speed	Max. 10,000 min <sup>-1</sup>	
Max. drilling diameter by rotary tool on gang tool post	10 mm dia.	
Max. tapping diameter by rotary tool on gang tool post	M8	
Gang tool spindle speed	Max. 9,000 min <sup>-1</sup>	
Max. chuck diameter of the back spindle	25 mm dia.	
Max. workpiece protrusion length from the back spindle	50 mm	
Max. drilling diameter in back machining	12 mm dia.	
Max. tapping diameter in back machining	M10	
Back spindle speed	Max. 10,000 min <sup>-1</sup>	
Tool capacity Standard (Maximum)	35 (59)	35 (43)
Cutting tool	7 - 13	7 - 9
Front drilling tools	4 - 23	4 - 13
Front cross drilling tools	7 - 12	7
Back drilling tools	6 - 35	6 - 25
Back cross drilling tools	4 - 6	4 - 6
Tool size		
Turning tool	16 mm sq./ 19 mm sq./	
Sleeve	25.4 mm sq./	
Chuck / bushing		
Spindle collet chuck	FC071-M	
Back spindle collet chuck	FC071-MK	
Guide bushing	FG521-M	
Rapid feed rate		
All axes (other than Z2)	32 m/ min	
Z2 axis	24 m/ min	
Motor		
For spindle drive	3.7/ 5.5 kW	
For driving rotary tools on the gang tool post	2.2 kW	
For back spindle drive	2.2/ 3.7 kW	
For driving rotary tools on the back tool post	1.0 kW	
Rated power consumption	13 kVA	
Total load current	33 A	
Main breaker capacity	60 A	
Pneumatic device		
Required pressure	0.5 MPa(5kgf/cm <sup>2</sup> )	
Flow rate	Up to 60 NL/min (Power on)	
	Up to 180 NL/min (With air blow)	
Tank capacity		
Tank capacity	0.8 L	
Coolant tank capacity	200 L	
Machine size		
Machine height	1,795 mm	
Required floor area	2,440×1,380 mm	
Required floor area	1,050 mm	
Required floor area	3,450 kg	

## Standard Accessories

Spindle chucking device	Cut-off tool breakage detector
Back spindle chucking device	Workpiece conveyor
Rotary tool spindle drive device of the gang tool post	Work light
Coolant tank (with level detector)	Rotary guide bushing drive device
Central lubrication device (with level detector)	Spindle cooling device
Machine relocation detector	Door lock

## Special Accessories

Rotary guide bushing device	Signal lamp
Knock-out device for workpieces with through-holes	3-color signal tower
Chip conveyor	Opposite tool post
Coolant flow rate detector	Medium-pressure coolant device
D25 dedicated tools	

## Standard NC Functions

D25 dedicated NC unit	15-inch touch panel screen
User disk space: 10 MB	Program storage capacity 160 m (64kB)
Tool offset pairs: 99 pairs	Preparation function
On-machine program check function	Run hour display
USB slot	Door lock function
Interference check function	Machine operation information display
Collision detection function	Spindle speed fluctuation detection function
Spindle constant surface speed control function	Tool nose radius compensation
B axis control function (type VIII)	Thermal displacement correction function

## Special Additional NC Functions

Back spindle chasing function	Variable lead thread cutting
Circular thread cutting	User macro
Drilling canned cycle	High-speed synchronized tapping function
Differential speed rotary tool function	Back spindle 1° indexing function
Spindle C-axis function	Back spindle C-axis function
Milling interpolation function	Helical interpolation function
Coordinate rotation command function	RS-232C connector
User disk space: 100 MB	Program storage capacity 4800 m (1920 kB)
Run using program in external memory	Tool life management I
Tool life management II	Network I/O function
Sub-micron command	Optional block skip (9 sets)
3D chamfering function	

## CITIZEN MACHINERY CO., LTD.

# CITIZEN

<b>JAPAN</b>	CITIZEN MACHINERY CO.,LTD. 4107-6 Miyota, Miyota-machi, Kitasaku-gun, Nagano-ken, 389-0206, JAPAN	TEL.81-267-32-5901 FAX.81-267-32-5908
<b>SOUTH ASIA / KOREA</b>	CITIZEN MACHINERY CO.,LTD. 4107-6 Miyota, Miyota-machi, Kitasaku-gun, Nagano-ken, 389-0206, JAPAN	TEL.81-267-32-5901 FAX.81-267-32-5908
<b>TAIWAN</b>	CINCOM MIYANO TAIWAN CO.,LTD. 10Fl., No.174, Fuh Sing N. Rd., Taipei, TAIWAN	TEL.886-2-2715-0598 FAX.886-2-2718-3133
<b>CHINA</b>	CITIZEN (CHINA) PRECISION MACHINERY CO.,LTD. 10058, XINHUA ROAD OF ZHOUCUN, ZIBO, SHANDONG, P.R. CHINA	TEL.86-533-6150560 FAX.86-533-6161379
<b>EUROPE-Germany</b>	CITIZEN MACHINERY EUROPE GmbH Mettinger Strasse 11, D-73728 Esslingen, GERMANY	TEL.49-711-3906-100 FAX.49-711-3906-106
<b>EUROPE-UK</b>	CITIZEN MACHINERY UK LTD 1 Park Avenue, Bushey, WD23 2DA, UK	TEL.44-1923-691500 FAX.44-1923-691599
<b>EUROPE-Italia</b>	CITIZEN MACCHINE ITALIA s.r.l. Via Guglielmo Marconi 47 24040 Comun Nuovo (BG), ITALY	TEL.39-035-877-738 FAX.39-035-876-547
<b>AMERICA</b>	MARUBENI CITIZEN-CINCOM INC. 40 Boroline Road Allendale, NJ 07401, U.S.A.	TEL.1-201-818-0100 FAX.1-201-818-1877

URL:<https://cmj.citizen.co.jp/>

All specifications are subject to change without prior notice. This product is an export control item subject to the foreign exchange and foreign trade act. Thus, before exporting this product, or taking it overseas, contact your CITIZEN machine dealer. Please inform your CITIZEN machine dealer in advance of your intention to re-sell, export or relocate this product. For the avoidance of doubt products includes whole or part, replica or copy, technologies and software. In the event of export, proof of approval to export by government or regulatory authority must be evidenced to CITIZEN. You can operate the machines after the confirmation of CITIZEN. CITIZEN, LFV, MultiStationMachiningCell and Ocean technology is a registered trademark of Citizen Watch Co., Japan.