

CITIZEN

**Cincom**

**L20XIIB5**

Sliding Headstock Type Automatic CNC Lathe



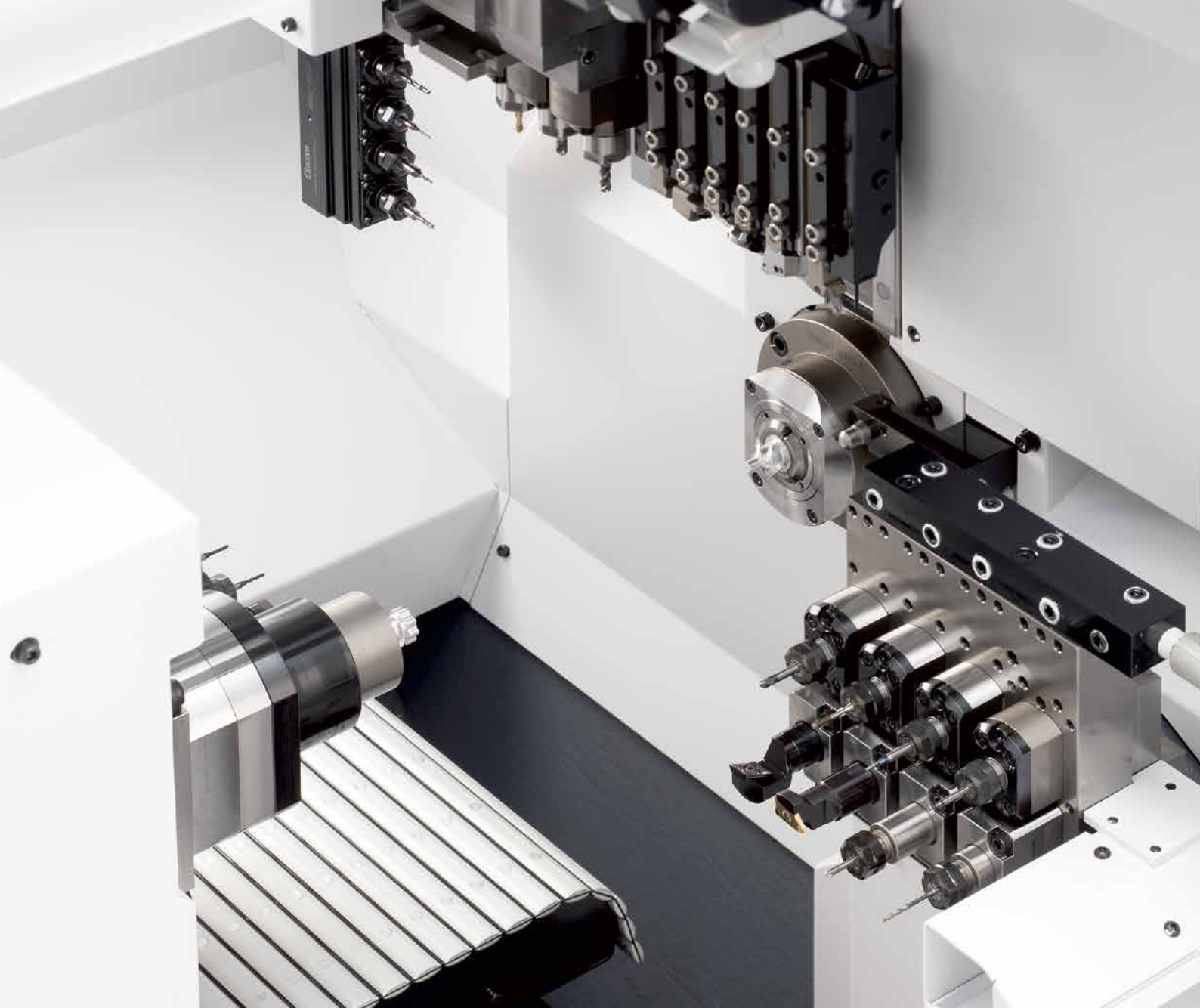

Cincom's best-selling L series machines have been relaunched with exciting new functions.

The L20 XIIB5 finally enables simultaneous 5-axis control, greatly expanding the machining range of CNC automatic lathes. Improved basic performance, along with great advances in ease of use.

### Improved basic performance

- B-axis tools expand the machining range for the front spindle to 110°. This allows more complex machining with higher accuracy.
- The number of turning tools is increased to six, resolving tool shortages.
- Thermal dimension changes reduced through thermal analysis. This enables continuous machining with stable accuracy.

### Ease of use

- The flip-up cutting room door provides a wide opening, and together with the door at the rear of the machine, allows easy access for tool setting.
- The coolant tank has been improved for easier chip cleaning.
- The tool pitches of the opposite tool post and back tool post have been widened to facilitate tool setting and reduce setup time.
- The operation panel has a large 15-inch touch panel. The new HMI (Human Machine Interface) allows intuitive operation.

### Improved Productivity

- The latest NC unit on the machine realizes simultaneous 5-axis control. Cycle times are shortened due to improved program processing capability.
- The higher output of the back spindle improves acceleration/deceleration, which helps to shorten cycle times.
- LFV can now be used for back machining, eliminating problems with chip entanglement.
- The IoT-friendly function incorporated in the machine enables configuration of an operation monitoring system using communication standards compliant with OPC-UA and MTConnect.
- The available peripheral units include motor-driven knock-out devices, loaders/unloaders, ATC units, and servo-driven chucking devices.

## Basic Construction

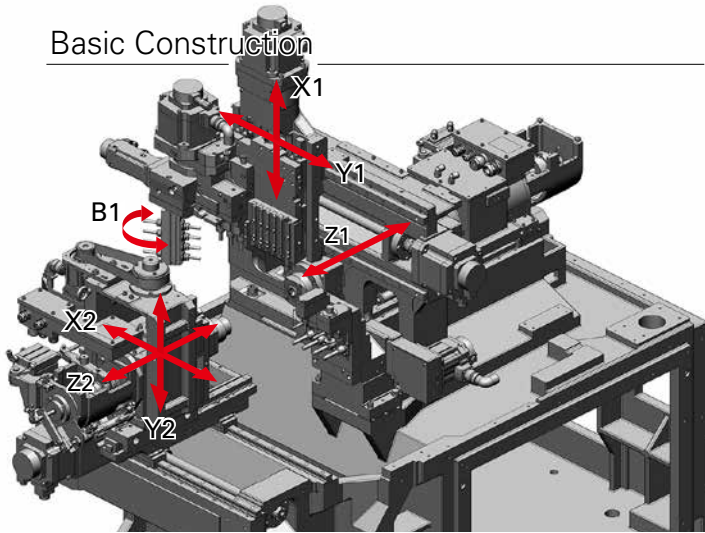

The B-axis machining range for the front spindle has been expanded to 110°. This provides greater flexibility in the machining balance, by reducing the number of tools assigned to back machining for example.

In addition, the number of turning tools has been increased from five to six, resolving tool shortages.

## Enable Simultaneous 5-axis control

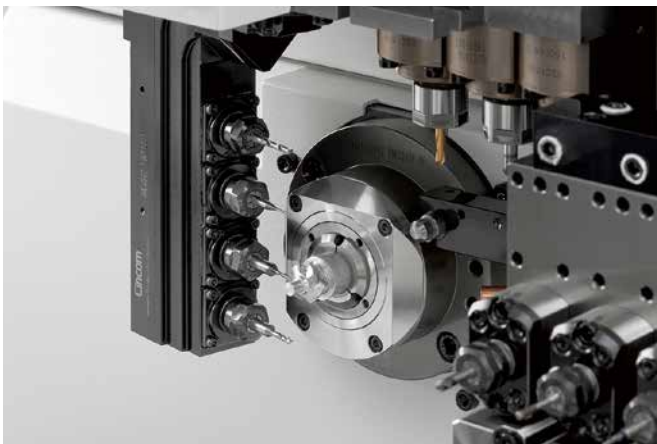

The latest NC unit is installed. This enables simultaneous 5-axis control, and machining of contoured surfaces with highly flexible tool movements.

In addition, program processing capability is greatly improved, and cycle times can be shortened.

## Intuitive and easy to use operation panel



A 15-inch touch panel is adopted, and the new HMI (Human Machine Interface) enables intuitive operation.

## Cutting room with improved operating convenience



The cutting room door is a flip-up type with a built-in damper, and provides a wide opening for good operating convenience. The larger window also improves visibility when the door is closed.

The rear of the machine now has a sliding door, making it easier to access the back side of the cutting room, which was previously difficult to reach.

## Advanced peripheral units for greater convenience



Motor-driven knock-out devices, loaders/unloaders, ATC units, servo-driven chucking devices, etc., are available. Peripheral units with greater ease of use support factory automation.

## LFV eliminates chip problems



LFV\* (low-frequency vibration cutting) technology is Citizen's original machining technology that breaks chips during cutting. It solves a variety of problems caused by chips, with LFV mode 1 best suited for machining of outer/inner diameters and grooves, LFV mode 2 best suited for micro-drilling that requires a high surface speed, and LFV mode 3 enabling vibration thread cutting.

Front side X1, Z1	Back side X2, Z2	LFV mode 1	LFV mode 2	LFV mode 3
✓	✓	✓	✓	✓

1. LFV machining cannot be performed with the Y axis.
2. LFV machining can be performed simultaneously on a maximum of 1 pair of axes.
3. For LFV machining with rotary tools, the "LFV function" and "rotary tool feed per revolution" options are required.

\* "LFV" is a registered trademark of Citizen Watch Co., Ltd.

# Machine specifications

Item	L20
	XIIB5
L20 - 3M12B5	
Max. machining diameter	20 mm Dia., 25 mm Dia. [1*] <sup>OP</sup>
Max. machining length GB	200 mm per chucking
25 mm Dia. spec.	188 mm per chucking
GBL	Max. 50 mm per chucking (GBL)
Max. front drilling diameter	10 mm Dia.
Max. front tapping diameter	M8 (cutting tap)
Spindle through-hole diameter	26.4 mm Dia.
Spindle speed	Max. 10,000 min <sup>-1</sup>
Max. chuck diameter of the back spindle	20 mm Dia., 25 mm Dia. [1*] <sup>OP</sup>
Max. taking-out length of the product	130 mm
Max. workpiece protrusion length from the back spindle	40 mm
Max. drilling diameter in back machining	8 mm Dia.
Max. tapping diameter in back machining	M8
Back spindle speed	Max. 10,000 min <sup>-1</sup>
Rotary tools on the gang tool post	
Maximum drilling diameter	8 mm Dia.
Max. tapping diameter	M6 (cutting tap)
Spindle speed	Max. 9,000 min <sup>-1</sup> (rated speed: 9,000 min <sup>-1</sup> )
Rotary tools on the opposite tool post*	
Maximum drilling diameter	φ5 mm
Max. tapping diameter	M4 (cutting tap)
Spindle speed	Max. 7,500 min <sup>-1</sup> (rated speed: 6,000 min <sup>-1</sup> )
Back rotary tool	
Maximum drilling diameter	φ5 mm
Max. tapping diameter	M4 (cutting tap)
Spindle speed	Max. 7,500 min <sup>-1</sup> (rated speed: 6,000 min <sup>-1</sup> )
Number of mountable tools	41
Turning tools on the gang tool post	6
Rotary tools on the gang tool post	21
Front drilling tools	6
Back drilling tools	8
Tool size	
Turning tools	12 mm sq. (13 mm sq., 16 mm sq.)
Sleeve	19.05 mm Dia.
Chuck / bushing	
Front spindle collet chuck	FC034-M, (FC071-M: 25 mm Dia. [1*] <sup>OP</sup> )
Back spindle collet chuck	FC034-M-K, (FC071-M-K: 25 mm Dia. [1*] <sup>OP</sup> )
Rotary tool collet chuck	ER11, ER16
Chuck for drill sleeve	ER11, ER16
Guide bushing	WFG206-M, DFG206M, (FG521-M: 25 mm Dia. [1*] <sup>OP</sup> )
Rapid traverse rate	
X1, Y1, Z1, X2, Z2 axis	32 m / min
Y2 axis	8 m / min
Motor	
For front spindle drive	2.2/ 3.7/ 5.5 kW (continuous/ 15 minute/ 10%ED ratings)
For back spindle drive	1.5/ 2.2/ 3.7 kW (continuous/ 40%ED/ 10%ED ratings)
For front rotary tool drive	0.75 kW
For back rotary tool drive	0.75 kW
For coolant pump	0.4 kW
Rated power consumption	8.8 KVA
Total load current	37 A
Main breaker capacity	60 A
Supply voltage	AC 200V ± 10%
Pneumatic device	
Required pressure	0.5 MPa
Required flow rate	52/ 65/ 197 NL / min (Power ON/ Normal/ With air blow)
Machine body dimensions	W 2,222 × D1,265 × H1,835 mm
Center height	1,050 mm
Machine weight	2,680 kg

\* Rotary tools on the opposite tool post are optional.

## Standard Accessories

Main spindle chucking unit	Back spindle chucking unit
Gang rotary tool driving unit	Back rotary tool drive
Rotary guide bushing drive device	Cut-off tool breakage detector
Coolant tank (with level detector)	Central lubrication device (with level detector)
Air-driven knock-out device for back machining	Machine relocation detector
Spindle cooling device	Door lock device
In-machine lighting	Automatic fire extinguisher

## Special accessories

Knock-out device for through-hole workpieces	Motor-driven knock-out unit for back machining
Rotary guide bushing device	Long workpiece device
Product unloader	Workpiece conveyor
Chip conveyor	Medium-pressure coolant device
High-pressure coolant device	Coolant flow rate detector
3-color signal tower	Servo-driven chucking device
Loader	LFV
ATC unit	Extended coolant tank unit

## Standard NC Functions

CINCOM SYSTEM M850LUC-V (Mitsubishi Electric)	
15-inch XGA touch panel	Program storage capacity: 160 m (64 kB)
Tool offset pairs: 99 pairs	Product counter: max. 8 digits
User disk space: 10 MB	Preparation function
Operating time display	Machine operation information display
B-axis control function	Back machining program skip function
Interference check	Collision detection function
Spindle speed fluctuation detection function	Spindle constant surface speed control function
Automatic power-off function	Spindle 1° indexing function
On-machine program check function	Tool nose radius compensation function
Eco indication	Corner chamfering/ Corner rounding
Multiple repetitive cycle for turning	USB slot and SD card slot

## Special Additional NC Functions

Variable lead thread cutting	Circular thread cutting
3D chamfering function	Geometric command function
Spindle synchronized control function	Spindle C-axis function
Milling interpolation function	Back spindle 1° indexing function
Back spindle C-axis function	Back spindle chasing function
Canned drilling cycle	Synchronized tapping phase alignment function
Synchronized tapping function	High-speed synchronized tapping function
Differential speed rotary tool function	Optional block skip (9 sets)
Tool life management I	Tool life management II
Program storage capacity: 1200 m (480 kB)	User disk space: 100 MB
Run using program in external memory	Sub-micron command
User macro	Helical interpolation function
Slant helical interpolation function	Hobbing function
Polygon function	Inch specifications
Sub-inch specifications	alkarttransfer
RS-232C connector	Rotary tool feed per revolution
Tool monitor function	

## CITIZEN MACHINERY CO., LTD.

# CITIZEN

<b>JAPAN</b>	CITIZEN MACHINERY CO., LTD. 4107-6 Miyota, Miyota-machi, Kitasaku-gun, Nagano-ken, 389-0206, JAPAN	TEL. 81-267-32-5901
<b>SOUTH ASIA / KOREA</b>	CITIZEN MACHINERY CO., LTD. 4107-6 Miyota, Miyota-machi, Kitasaku-gun, Nagano-ken, 389-0206, JAPAN	TEL. 81-267-32-5901
<b>TAIWAN</b>	CINCOM MIYANO TAIWAN CO., LTD. 10FL., No.174, Fuh Sing N. Rd., Taipei, TAIWAN	TEL. 886-2-2715-0598
<b>CHINA</b>	CITIZEN (CHINA) PRECISION MACHINERY CO., LTD. 10058, XINHUA ROAD OF ZHOUCUN, ZIBO, SHANDONG, P.R. CHINA	TEL. 86-533-6150560
<b>GERMANY</b>	CITIZEN MACHINERY EUROPE GmbH Mettinger Strasse 11, D-73728 Esslingen, GERMANY	TEL. 49-711-3906-100
<b>UK</b>	CITIZEN MACHINERY UK LTD 1 Park Avenue, Bushey, WD23 2DA, UK	TEL. 44-1923-691500
<b>ITALIA</b>	CITIZEN MACCHINE ITALIA s.r.l. Via Guglielmo Marconi 47 24040 Comun Nuovo (BG), ITALY	TEL. 39-035-877738
<b>FRANCE</b>	HESTIKA FRANCE S.A.S. 1385 Avenue du Môle Z.A.E des Lacs 3, 74130 AYZE, FRANCE	TEL. 33-4-5098-5269
<b>SPAIN</b>	EGASCA, S.A. Poligono Industrial Erisono 2, 20600 Eibar (Gipuzkoa), SPAIN	TEL. 33-4-5098-5269
<b>AMERICA</b>	MARUBENI CITIZEN-CINCOM INC. 40 Boroline Road Attendale, NJ 07401, U.S.A.	TEL. 1-201-818-0100

URL: <https://cmj.citizen.co.jp/>

All specifications are subject to change without prior notice. This product is an export control item subject to the foreign exchange and foreign trade act. Thus, before exporting this product, or taking it overseas, contact your CITIZEN machine dealer. Please inform your CITIZEN machine dealer in advance of your intention to re-sell, export or relocate this product. For the avoidance of doubt products includes whole or part, replica or copy, technologies and software. In the event of export, proof of approval to export by government or regulatory authority must be evidenced to CITIZEN. You can operate the machines after the confirmation of CITIZEN. CITIZEN, LFV, MultiStationMachiningCell and Ocean technology is a registered trademark of Citizen Watch Co., Japan.